

100 Watt, Universal Input, PFC Converter

ON Semiconductor



ON Semiconductor®

<http://onsemi.com>

APPLICATION NOTE

General Description

This 100 watt converter demonstrates the wide range of features found on the NCP1650. This chip is capable of controlling PFC converters well into the kilowatt range.

In addition to excellent power factor, this chip offers fixed frequency operation in continuous and discontinuous modes of operation. It has a wide variety of protection features, including instantaneous current limiting, average current limiting, and true power limiting.

This unit will provide 400 V of well regulated power from an input source with a frequency range from 50 Hz to 60 Hz, and a voltage range of 85 V_{rms} to 265 V_{rms}. It is fully self contained and includes a high voltage start-up circuit, and bias supply that operates off of the boost inductor.

Features

- Fixed Frequency Operation
- Shutdown Circuit
- Operation Over the Universal Input Range
- Multiple Protection Schemes
- True Power Limiting
- Start-Up and Bias Circuits Included

Circuit Description

Start-Up Circuit

The start-up circuit allows the unit to use power from the input line to begin operation, and then shuts down to allow operation off of the bias winding, which reduces losses in the circuit.

The start-up circuit has three modes of operation. One is used for starting the NCP1650 when the chip is functional, one is for bias power during shutdown operation, and the third is the off state.

When power is initially applied to the unit, the gate of the pass transistor will be high, and the FET will be fully enhanced. The current into the V_{CC} capacitance at pin 1 will be limited by the three 10 kΩ resistors in series with the FET.

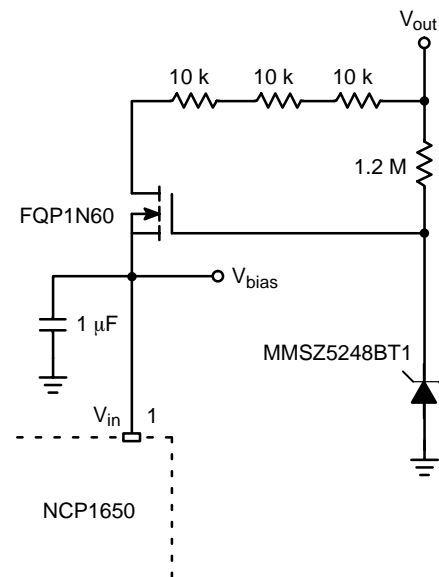

Figure 1. Start-Up Circuit Schematic

This circuit will provide current as long as the FET is enhanced. For this to occur, the gate to source voltage must be greater than the gate threshold voltage. For this device that value is nominally, 4.0 V. The zener breakdown voltage is 18 V, so the FET will turn off at:

$$V_{chg\ max} = 18\ V - 4.0\ V = 14\ Volts$$

As the output capacitor is charged up during the turn-on sequence, the bias supply voltage will also increase until the source of the FET exceeds 14 V. At this point, the FET will cease conduction, and all of the V_{CC} power will be supplied via the bias circuit from the power inductor.

If the unit is commanded into the shutdown mode, the chip will reduce its bias current to 0.5 mA and the start-up circuit will then maintain a regulated voltage of approximately 14 V on the V_{CC} pin until the device becomes operational.

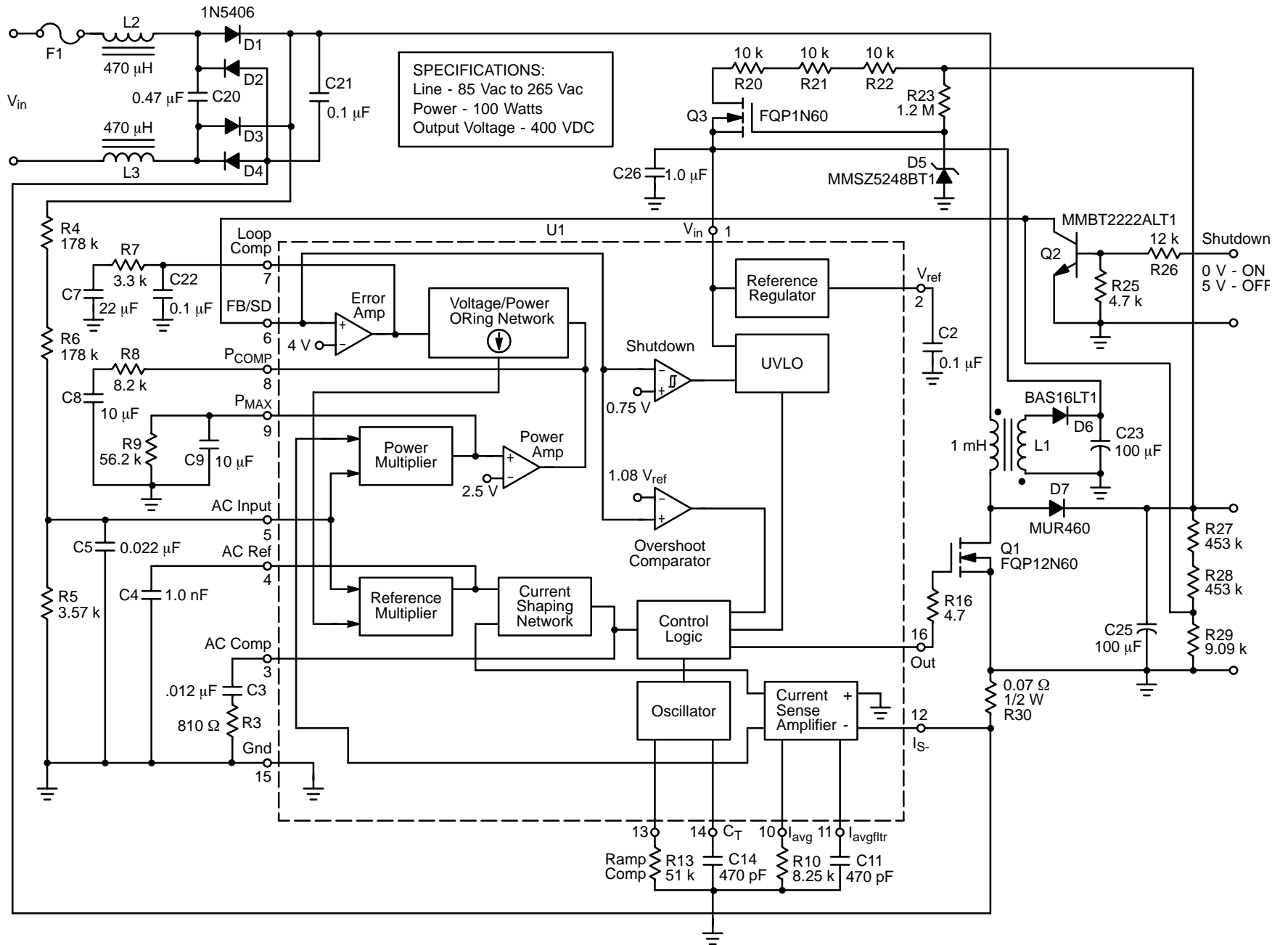

Figure 1. Applications Circuit Schematic

Voltage Regulation Loop

The output voltage is sensed and reduced to the reference level by the resistive divider consisting of R27, R28 and R29. The output voltage of this divider is sensed by the non-inverting input of the error amplifier and compared to the internal 4.0 V reference.

Assuming that the unit is not in a power limit condition, the voltage error signal will dominate the loop and be fed through the OR'ing network to provide one of the inputs to the reference multiplier. The other reference multiplier input is the divided down rectified AC input signal.

The output of this multiplier is a haversine signal that is an accurate replica of the input AC signal. The current shaping network compares the average current from the current sense amplifier to the reference voltage and forces this current to follow the AC reference voltage. The current out of the current sense amplifier is filtered at a frequency that is less than the switching frequency, but greater than the rectified line frequency.

This current is fed into the output filter capacitor(s) that filter it to a DC level.

Power Regulation Loop

The power multiplier generates the product of the input current (from the current sense amplifier) and the AC rectified input voltage, to generate a signal that represents the input power of the unit. This signal is filtered to a frequency of less than the line frequency, so that its output is a DC level.

If the load is increased to a level that exceeds the maximum power limit of the circuit, the output of the power multiplier will reach 2.5 V and the output of the power error amplifier will go to some level above ground. This signal will then override the signal from the voltage error amplifier (labeled "error amp" on the schematic), and will dominate the OR'ing network.

This signal then determines the level of the reference signal out of the reference multiplier, and determines the input current to the power converter. It should be noted that as this is a boost converter, the power limit circuit will only fold back the output voltage until it reaches the level of the peak line voltage. At this point the converter will shut down, but the input voltage will continue to charge the output capacitors through the rectifier.

Shutdown Circuit

The shutdown circuit will inhibit the operation of the power converter and put the NCP1650 into a low power shutdown mode. To activate this circuit, apply 5.0 V to the red test point, with the black jack being "ground". Be aware that the black jack is actually hot as it is connected to the output of the input bridge rectifiers. An isolated 5.0 V supply should be used.

If this circuit is not being used, the terminals can be left open, as there is enough resistance built in to the circuit to keep the transistor (Q2) in its off state.

PCB

The printed circuit board Gerber files are located on the ON Semiconductor website under the name NCP650-PCB1.

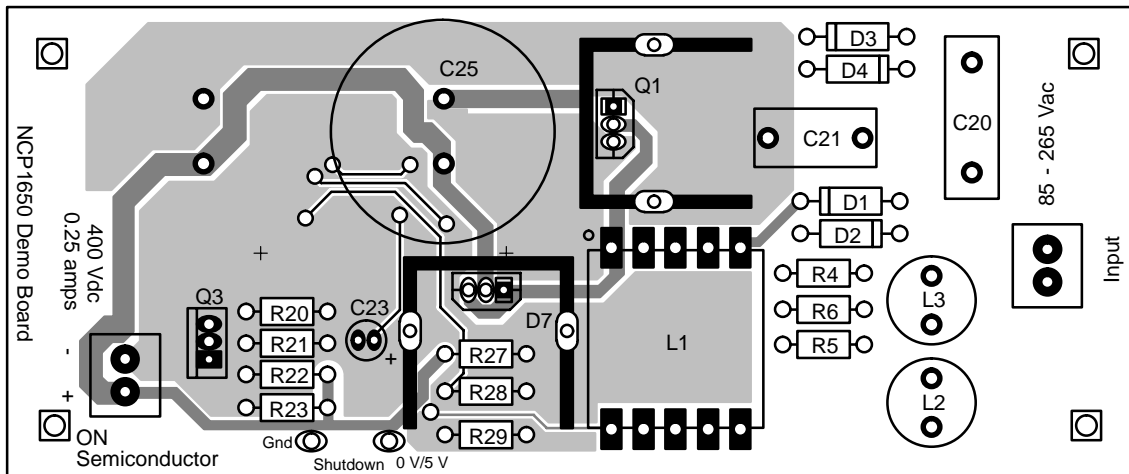

AND8106/D

Table 1.

Ref Des	Description	Part Number	Manufacturer
C2	Cap, Ceramic, Chip, 0.1 μ F, 50 V	C1608X7R1H104KT	TDK
C3	Cap, Ceramic, Chip, .012 μ F, 50 V	C1608X7R1H123KT	TDK
C4	Cap, Ceramic, Chip, 1.0 nF, 50 V	C1608X7R1H102K	TDK
C5	Cap, Ceramic, Chip, 0.022 μ F, 50 V	C1608X7R1H223K	TDK
C7	Cap, Ceramic, Chip, 22 μ F, 6.3 V	C3225X5R0J226MT	TDK
C8	Cap, Ceramic, Chip, 10 μ F, 10 V	C3225X5R1A106MT	TDK
C9	Cap, Ceramic, Chip, 4.7 μ F, 10 V	C3216X5R1A475KT	TDK
C11	Cap, Ceramic, Chip, 470 pF, 50 V	C1608C0G1H471JT	TDK
C14	Cap, Ceramic, Chip, 470 pF, 50 V	C1608C0G1H471JT	TDK
C20	0.47 μ F, 275 Vac, X Cap	ECQ-U2A474ML	Panasonic
C21	Cap, Polyprop, 0.1 μ F, 400 Vdc	MKP1841-410-405	Vishay-Sprague
C22	Cap, Ceramic, Chip, 0.1 μ F, 50 V	C1608X7R1H104KT	TDK
C23	100 μ F, Alum Elect, 25 V	ECA-1EM101I	Panasonic
C25	100 μ F, Alum Elect, 450 V	ECO-S2WP100EX	Panasonic
C26	Cap, Ceramic, Chip, 1.0 μ F, 25 V	C3216X7R1E105KT	TDK
D1-D4	Diode, Rectifier, 600 V, 3.0 A	1N5406	ON Semiconductor
D5	Diode, Zener, 18 V, Axial Lead	MMSZ5248BT1	ON Semiconductor
D6	Diode, Signal, 75 V, 200 mA, SOT-23	BAS19LT1	ON Semiconductor
D7	Diode, Ultra-Fast, 600 V, 8.0 A	MURHF860CT	ON Semiconductor
F1	Fuse, 2.0 A, 250 Vac	1025TD2A	Bussman
L1	Inductor, 1000 μ H, 2.4 A Max	CTX22-15557	Coiltronics
L2	2.5 A Sat, 100 μ H Inductor, Diff Mode	TSL1315S-101K2R5	TDK
L3	2.5 A Sat, 100 μ H Inductor, Diff Mode	TSL1315S-101K2R5	TDK
Q1	FET, 10.5 A, 0.7 Ω , 600 V, N-chl	FQP12N60	Fairchild
Q2	Bipolar Transistor, 50 V	MMBT2222ALT1	ON Semiconductor
Q3	FET, 1.0 A, 600 V, N-chl	FQP1N60	Fairchild
R3	Resistor, SMT, 810 Ω	CRCW1206810JNTA	Vishay
R4	Resistor, Axial Lead, 178 k, _ Watt, 1%	CMF-55-178K00FKRE	Vishay
R5	Resistor, Axial Lead, 3.57 k, _ Watt, 1%	CMF-55-3K5700FKBF	Vishay
R6	Resistor, Axial Lead, 178 k, _ Watt, 1%	CMF-55-178K00FKRE	Vishay
R7	Resistor, SMT, 8.6 k	CRCW12068K60JNTA	Vishay
R8	Resistor, SMT, 9.1 k	CRCW12069K10JNTA	Vishay
R9	Resistor, SMT, 56.2 k, 1%	CRCW120656K2FKTA	Vishay
R10	Resistor, SMT, 8.25 k, 1%	CRCW12068K2FKTA	Vishay
R13	Resistor, SMT, 51 k	CRCW120651K0JNTA	Vishay
R16	Resistor, SMT, 10	CRCW1206100JRE4	Vishay
R20	Resistor, Axial Lead, 10 k, _ Watt	CCF-07-103J	Vishay
R21	Resistor, Axial Lead, 10 k, _ Watt	CCF-07-103J	Vishay
R22	Resistor, Axial Lead, 10 k, _ Watt	CCF-07-103J	Vishay
R23	Resistor, Axial Lead, 1.2 M, _ Watt	CCF-07-125J	Vishay
R25	Resistor, SMT, 4.7 k	CRCW12064K70JNTA	Vishay

AND8106/D

Table 1. (continued)

Ref Des	Description	Part Number	Manufacturer
R26	Resistor, SMT, 12 k	CRCW120612K0JNTA	Vishay
R27	Resistor, Axial Lead, 453 k, _ Watt, 1%	CMF-55-453K00FKBF	Vishay
R28	Resistor, Axial Lead, 453 k, _ Watt, 1%	CMF-55-4533F	Vishay
R29	Resistor, Axial Lead, 9.09 k, _ Watt, 1%	CCF-55-9K09FHR362	Vishay
R30	1.0 W, 0.07 Ω , 1% Resistor	WSL2512R0700FTB	Vishay
U1	PFC Controller	NCP1650	ON Semiconductor
	Hardware		
H1	Printed Circuit Board	NCP1650-PWB1	www.onsemi.com
H2	Connector	171602	Weidmuller
H3	Connector	171602	Weidmuller
H4	Test Point, Red	5005	Keystone
H5	Test Point, Black	5006	Keystone
H6	Standoff, 4-40, Alum, Hex, .500 Inches	8403	HH Smith
H7	Standoff, 4-40, Alum, Hex, .500 Inches	8403	HH Smith
H8	Standoff, 4-40, Alum, Hex, .500 Inches	8403	HH Smith
H9	Standoff, 4-40, Alum, Hex, .500 Inches	8403	HH Smith
H10	Heatsink, TO-220	590302B03600	Aavid Thermalloy
H11	Heatsink, TO-220	590302B03600	Aavid Thermalloy

Table 2. Vendor Contacts

Vendor	U.S. Phone/Internet
ON Semiconductor	1-800-282-9855 www.onsemi.com/
TDK	1-847-803-6100 www.component.tdk.com/
Vishay	www.vishay.com/
Bussman (Cooper Ind.)	1-888-414-2645 www.cooperet.com/
Coiltronics (Cooper Ind.)	1-888-414-2645 www.cooperet.com/
Fairchild	www.fairchildsemi.com/
Panasonic	www.eddieray.com/panasonic/
Weidmuller	www.weidmuller.com/
Keystone	1-800-221-5510 www.keyelco.com/
HH Smith	1-888-847-6484 www.hhsmith.com/
Aavid Thermalloy	www.aavid.com/

Performance Data

Table 3. Regulation

Line/Load	No Load	50 Watts	100 Watts
85 V_{rms}	405.5	405.1	403.9
115 V_{rms}	405.6	405.2	404.3
220 V_{rms}	405.4	405.5	404.9
265 V_{rms}	438.4	405.5	405

AND8106/D

Table 4. Harmonics and Distortion

	115 Vac, 100 Watts		230 Vac, 100 Watts	
	V harmon	A harm. %	V harmon	A harm. %
2 nd	0.084	0.03	0.169	0.12
3 rd	0.505	2.8	0.722	2.6
5 th	0.482	1.3	0.132	4.4
7 th	0.168	0.5	0.075	0.17
9 th	0.074	0.17	0.133	0.23
11 th	0.088	0.13	0.134	0.17
13 th	0.212	0.27	0.073	0.15
15 th	0.324	0.37	0.265	0.28
17 th	0.413	0.35	0.488	0.32
19 th	0.632	0.31	1.12	0.44
PF	-	0.998	-	0.9928
THD (A)	-	3.68	-	6.2
I _{fund}	-	0.919	-	0.451

Table 5. Efficiency

	85 V _{rms}	115 V _{rms}	230 V _{rms}	265 V _{rms}
P _{in} @ No Load	2.87	4.06	5.07	5.11
P _{in}	108.8	106.9	103.2	103.7
V _o	403.2	404.3	404.9	405
I _o	0.246	0.246	0.243	0.244
Efficiency	0.912	0.930	0.953	0.953

Notes

ON Semiconductor and  are registered trademarks of Semiconductor Components Industries, LLC (SCILLC). SCILLC reserves the right to make changes without further notice to any products herein. SCILLC makes no warranty, representation or guarantee regarding the suitability of its products for any particular purpose, nor does SCILLC assume any liability arising out of the application or use of any product or circuit, and specifically disclaims any and all liability, including without limitation special, consequential or incidental damages. "Typical" parameters which may be provided in SCILLC data sheets and/or specifications can and do vary in different applications and actual performance may vary over time. All operating parameters, including "Typicals" must be validated for each customer application by customer's technical experts. SCILLC does not convey any license under its patent rights nor the rights of others. SCILLC products are not designed, intended, or authorized for use as components in systems intended for surgical implant into the body, or other applications intended to support or sustain life, or for any other application in which the failure of the SCILLC product could create a situation where personal injury or death may occur. Should Buyer purchase or use SCILLC products for any such unintended or unauthorized application, Buyer shall indemnify and hold SCILLC and its officers, employees, subsidiaries, affiliates, and distributors harmless against all claims, costs, damages, and expenses, and reasonable attorney fees arising out of, directly or indirectly, any claim of personal injury or death associated with such unintended or unauthorized use, even if such claim alleges that SCILLC was negligent regarding the design or manufacture of the part. SCILLC is an Equal Opportunity/Affirmative Action Employer.

PUBLICATION ORDERING INFORMATION

Literature Fulfillment:

Literature Distribution Center for ON Semiconductor
P.O. Box 5163, Denver, Colorado 80217 USA
Phone: 303-675-2175 or 800-344-3860 Toll Free USA/Canada
Fax: 303-675-2176 or 800-344-3867 Toll Free USA/Canada
Email: ONlit@hibbertco.com

N. American Technical Support: 800-282-9855 Toll Free USA/Canada

JAPAN: ON Semiconductor, Japan Customer Focus Center
2-9-1 Kamimeguro, Meguro-ku, Tokyo, Japan 153-0051
Phone: 81-3-5773-3850

ON Semiconductor Website: <http://onsemi.com>

For additional information, please contact your local Sales Representative.